



INTERNATIONAL APPLICATION PUBLISHED UNDER THE PATENT COOPERATION TREATY (PCT)

(51) International Patent Classification ⁶ : C12Q 1/68	A1	(11) International Publication Number: WO 97/27329 (43) International Publication Date: 31 July 1997 (31.07.97)
<p>(21) International Application Number: PCT/US97/01219</p> <p>(22) International Filing Date: 24 January 1997 (24.01.97)</p> <p>(30) Priority Data: 08/592,120 26 January 1996 (26.01.96) US</p> <p>(71) Applicant: THE UNIVERSITY OF CHICAGO [US/US]; 5801 S. Ellis, Chicago, IL 60637 (US).</p> <p>(72) Inventors: MIRZABEKOV, Andrei; Apartment 1, Profsoyuznaya Street, 43, Moscow, 117420 (RU). YERSHOV, Genadiy; Apartment 309, Korpus 1121, Zelenograd, 103460 (RU). ZASLAVSKY, Alexander; Apartment F-403, 4695 E. Louisiana Avenue, Denver, CO 80222 (US). GUSCHIN, Dimitry; Apartment 205, 16 W. 505 Mockingbird Lane, Hinsdale, IL 60521 (US). TIMOFEEV, Edward; Building 3, Apartment 220, Shosseynaya Street, 19, Moscow, 109548 (RU). FLORENTIEV, Vladimir; Apartment 73, 1-st Samotechnyi per., 2, Moscow, 103473 (RU). KIRILLOV, Eugene; Apartment 115, Ostrovityaninova Street, 35, Moscow, 117411 (RU).</p> <p>(74) Agent: CHERSKOV, Michael, J.; Cherskov & Flaynik, The Civic Opera Building, Suite 1447, 20 North Wacker Drive, Chicago, IL 60606 (US).</p>	<p>(81) Designated States: CA, DE, GB, RU, SE, European patent (AT, BE, CH, DE, DK, ES, FI, FR, GB, GR, IE, IT, LU, MC, NL, PT, SE).</p> <p>Published <i>With international search report.</i></p>	
<p>(54) Title: A RAPID METHOD TO DETECT DUPLEX FORMATION IN SEQUENCING BY HYBRIDIZATION METHODS</p> <p>(57) Abstract</p> <p>A method for determining the existence of duplexes of oligonucleotide complementary molecules is provided whereby a plurality of immobilized oligonucleotide molecules, each of a specific length and each having a specific base sequence, is contacted with complementary, single stranded oligonucleotide molecules to form a duplex so as to facilitate intercalation of a fluorescent dye between the base planes of the duplex. The invention also provides for a method for constructing oligonucleotide matrices comprising confining light sensitive fluid to a surface, exposing said light-sensitive fluid to a light pattern so as to cause the fluid exposed to the light to coalesce into discrete units and adhere to the surface; and contacting each of the units with a set of different oligonucleotide molecules so as to allow the molecules to disperse into the units.</p>		

FOR THE PURPOSES OF INFORMATION ONLY

Codes used to identify States party to the PCT on the front pages of pamphlets publishing international applications under the PCT.

AM	Armenia	GB	United Kingdom	MW	Malawi
AT	Austria	GE	Georgia	MX	Mexico
AU	Australia	GN	Ghana	NE	Niger
BB	Barbados	GR	Greece	NL	Netherlands
BE	Belgium	HU	Hungary	NO	Norway
BF	Burkina Faso	IE	Ireland	NZ	New Zealand
BG	Bulgaria	IT	Italy	PL	Poland
BJ	Benin	JP	Japan	PT	Portugal
BR	Brazil	KE	Kenya	RO	Romania
BY	Belarus	KG	Kyrgyzstan	RU	Russian Federation
CA	Canada	KP	Democratic People's Republic of Korea	SD	Sudan
CF	Central African Republic	KR	Republic of Korea	SE	Sweden
CG	Congo	KZ	Kazakhstan	SG	Singapore
CH	Switzerland	LK	Lithuania	SI	Slovenia
CI	Côte d'Ivoire	LJ	Liechtenstein	SK	Slovakia
CM	Cameroon	LX	Sri Lanka	SN	Senegal
CN	China	LR	Liberia	SZ	Swaziland
CS	Czechoslovakia	LT	Lithuania	TD	Chad
CZ	Czech Republic	LU	Luxembourg	TG	Togo
DE	Germany	LV	Latvia	TJ	Tajikistan
DK	Denmark	MC	Monaco	TT	Trinidad and Tobago
EE	Estonia	MD	Republic of Moldova	UA	Ukraine
ES	Spain	MG	Madagascar	UG	Uganda
FI	Finland	ML	Mali	US	United States of America
FR	France	MN	Mongolia	UZ	Uzbekistan
GA	Gabon	MR	Mauritania	VN	Viet Nam

**A RAPID METHOD TO DETECT DUPLEX FORMATION
IN SEQUENCING BY HYBRIDIZATION METHODS**

CONTRACTUAL ORIGIN OF THE INVENTION

The United States Government has rights in this invention
5 pursuant to Contract No. W-31-109-ENG-38 between the U.S.
Department of Energy and the University of Chicago representing
Argonne National Laboratory.

BACKGROUND OF THE INVENTION

1. Field of the Invention

10 This invention relates to a method for rapidly detecting the
presence of duplex formation between single stranded nucleotide
macromolecules, and more specifically, this invention relates to a
method for using oligonucleotide arrays to rapidly detect duplex

formation of oligonucleotide sequences. This invention also relates to a simple procedure for producing the oligonucleotide-arrays.

5 **2. Background of the Invention**

Present techniques for determining the existence of target sequences in patient DNA are complex, inefficient and somewhat time consuming. For example, one multi-step DNA sequencing approach, the Maxam and Gilbert method, involves first labeling
10 DNA, and then splitting the DNA with a chemical, designed to alter a specific base, to produce a set of labeled fragments. The process is repeated by cleaving additional DNA with other chemicals specific for altering different bases, to produce additional sets of labeled fragments. The multiple fragment sets then must
15 be run side-by-side in electrophoresis gels to determine base sequences.

Another sequencing method, the dideoxy procedure, based on Sanger, et al. *Proc. Natl. Acad. Sci. USA* 74, 5463-7 (1977) first requires the combination of a chain terminator as a limiting
20 reagent, and then the use of polymerase to generate various length molecules, said molecules later to be compared on a gel. The accompanying lengthy electrophoresis procedures further detracts from the utility of this method as a fast and efficient sequencing tool.

25 A more recently developed sequencing strategy involves sequencing by hybridization on oligonucleotide microchips, or matrices, (SHOM) whereby DNA is hybridized with a complete set of oligonucleotides, which are first immobilized at fixed posi-

tions on a glass plate or polyacrylamide gel matrix. There are drawbacks to this technique, however. For instance, given that short nucleotide sequences are repeated rather frequently in long DNA molecules, the sequencing of lengthy genome strings is not
5 feasible via SHOM. Also, hybridization with short oligonucleotides is affected by hairpin structures in DNA.

Furthermore, SHOM requires the utilization of high volume substrates containing many thousands of cells. If immobilized octamers are utilized to determine the positions of each of the
10 four bases in genomic DNA, for example, then 4^8 or 65,536 such octamers, themselves which would need to be previously fabricated, would have to be immobilized in individual cells on the gel matrix.

The production of literally thousands of these cells on the
15 polyacrylamide substrates is problematic. First, these cells must be accurately spaced relative to one another. Second, these cells must be of sufficient depth and volume to hold predetermined amounts of the oligonucleotide. Cell sizes can range from 25 microns (μm) to 1000 μm .

20 Typically, cells are produced in a myriad of ways. Two-dimensional scribing techniques and laser evaporation are two typical methods of cell formation. Mechanical scribing techniques are limited, however, in that the smallest structures which can be produced via this method are approximately 100 μm x 100 μm .
25 Lasers applications, because of their expense, also are limiting. Furthermore, both of these procedures require complex equipment and experienced personnel.

A need exists in the art to provide a rapid and efficient

method for detecting the existence of complementary sequences to target DNA strands. This detection method should be performed using standard reagents found in a typical biochemistry facility. A need also exists for a method to produce accurate polyacrylamide matrices to be used in the above-disclosed duplex detection method. Such a matrix production method also must be simple enough to be performed in typically-equipped biochemical laboratories.

SUMMARY OF THE INVENTION

10 It is an object of the present invention to provide a method for rapidly detecting the formation and existence of duplexes between complementary nucleotide sequence strands that overcomes many of the disadvantages and reliability shortcomings of the prior art.

15 Another object of the present invention is to provide a method for the detection of DNA duplexes. A feature of the invention is the use of intercalating dyes. An advantage of the invention is the rapid detection of duplexes using typically-outfitted laboratories to perform standard procedures with common reagents.

20 Yet another object of the present invention is to provide a highly efficient method for detecting DNA duplexes. A feature of the invention is contacting a DNA duplex, contained on a high-volume support substrate, with an intercalating agent. An advantage of the invention is the enhanced ability to detect small amounts of formed DNA duplexes using standard, low-cost laboratory reagents.

25 Still another object of the present invention is to provide a

method for producing a polyacrylamide matrix having thousands of individual and well defined holding cells. A feature of the invention is the use of mask-controlled photo-polymerization processes. An advantage of the invention is the rendering of high numbers of precise cell geometries and at high densities.

Briefly, the invention provides for a method for determining the existence of duplexes of oligonucleotide complementary molecules comprising constructing a plurality of different oligonucleotide molecules each of a specific length and each having a specific base sequence; supplying a matrix having a plurality of cells adapted to receive and immobilize the oligonucleotide molecules; immobilizing the different oligonucleotide molecules in the cells to fill the cells; contacting the now-filled cells with single stranded oligonucleotide molecules to form a duplex; contacting the duplex with an intercalating agent; and observing fluorescence levels emanating from the now-contacted duplex.

The invention also provides for a method for constructing oligonucleotide matrices comprising confining light sensitive fluid to a surface, exposing said light-sensitive fluid to a light pattern so as to cause the fluid exposed to the light to coalesce into discrete units and stick to the surface; and contacting each of the units with a set of different oligonucleotide molecules so as to allow the molecules to disperse into the units.

BRIEF DESCRIPTION OF THE DRAWING

The invention together with the above and other objects and advantages will be best understood from the following detailed description of the preferred embodiment of the invention shown in the accompanying drawing, wherein:

FIG. 1 is an elevated view of an polyacrylamide matrix assembly, in accordance with the present invention; and

FIG. 2 is a magnified view of the polyacrylamide matrix assembly illustrated in FIG. 1, in accordance with the present
5 invention;

FIG. 3 is a plan view of a gel matrix, manufactured in accordance with the present invention;

FIGS. 4 A-B is a schematic view of an intercalating compound revealing a duplexed pair of oligonucleotide molecules
10 juxtaposed to a polyacrylamide matrix, in accordance with the present invention; and

FIG. 5 is a plan view of a gel matrix disclosing the existence of duplexes when fluorescently labeled oligomer (I) is used, and when intercalating dye (II) is used to detect duplexes, in accordance with the present invention.
15

DETAILED DESCRIPTION OF THE INVENTION

This invention involves incorporating intercalating techniques with processes for sequencing genetic material by hybridization methods (SBH) so as to produce a simple low resolution
20 procedure for duplex formation analysis. This invention also teaches a method to produce polyacrylamide matrices having thousands of microscopic-sized, precisely configured and positioned holding cells designed to contain predetermined quantities of oligonucleotide mixtures.

25 The inventors have developed a method of using a mask-controlled photo-polymerization process to create micro-matrix topologies. The resulting micro-matrices are used to immobilize specific oligonucleotide strands designed to form duplexes with

target DNA. The duplexes are contacted with an intercalating substance or dye to alert clinicians to the presence of duplexes.

Array Manufacturing Detail

The array manufacturing method, noted supra, incorporates a
5 modified Methylene Blue induced photo-polymerization procedure whereby a polyacrylamide solution is prepared and then configured into desired shapes and sizes for subsequent polymerization.

The production of gel-matrices involves the construction of polymerization units into which prepared acrylamide fluids are
10 placed. One exemplary polymerization unit is depicted in FIG. 1, as numeral 10, and partially magnified in FIG. 2.

In one embodiment of the invention, photo-polymerizations are performed on a solution containing 40 percent (between 30-45 percent, is suitable) acrylamide/Methylene Bis-Acrylamide (30:1)
15 stock solution and 0.04 percent Methylene blue stock solution in water. The stock acrylamide solution is diluted with water to a concentration ranging from 4 to 8 percent and subsequently degassed with a water pump for 10 minutes. The gel matrix is prepared from a standard mixture of 0.5 μ l 0.04 percent Methylene
20 blue solution, 1 ml acrylamide solution and 10 μ l N,N,N',N' - tetramethylethilendi-amine (TEMED), from Aldrich (Milwaukee, WI).

The resulting, liquid (prepolymerized) mixture 12 is applied to a first surface of a quartz substrate 14, which is previously
25 manipulated to contain a photomask. The preparation of the quartz substrate 14 involves applying a mask 20 to the first surface of the substrate 14, and then pretreating the first surface with an anti-wetting agent or an agent to increase the hydropho-

bicity of the surface. One such anti-wetting agent is a 2 percent solution of dimethyldichlorosilane in 1,1,1-trichloroethane, having the trade name Repel-Silan™, and manufactured by Pharmacia Biotech of Uppsala, Sweden. Another suitable anti-wetting agent is trimethylchlorosilane. Two identical spacers 18, made from an inert material such as Teflon, of 20 μm thickness are placed on peripheral edges of the first surface of the quartz substrate so as to form a pan-like container to confine the mixture 12. As such, a myriad of spacer thicknesses can be employed, depending on the final desired thickness of the polynucleotide chip.

A glass microscope slide 18, first pretreated with a material to attach polyacrylamide to glass, is placed on top of the spacers 16 to form a glass chamber 10. An exemplary pretreatment material is γ-Methacryloxy-propyl-trimethoxysilane, manufactured as Bind Silane by Pharmacia. This entire assembly or chamber 10 is fastened together via a myriad of fastening means (not shown), such as paper clips, tape, or inert adhesive.

A first surface of the quartz substrate 14 has a nontransparent mask (e.g., comprised of an inert opaque material such as chrome coating or permanent ink), containing a (grid) 20 defining a pattern of the desired topology. The grid 20 is applied to the mask coating surface of the quartz substrate 14 either by hand with a fine point marker or by photolithography, with the size of the gel elements defined by the dimensions of the transparent squares etched into the mask.

An exemplary grid is depicted in FIG. 3. Dimensions labeled as element "A" are the sizes of gel cells while elements "B" are

illustrated as the spaces between the cells. The mask is designed to block the light, used in the light-induced acrylamide polymerization process, in the spaces "B" between the gel units 22 where gel coalescence is not desired.

- 5 Various sizes of gel cells were fabricated on separate masks, as disclosed in Table 1, below.

Table 1: Various Gel and Space Dimensions Obtained Via the Invented Process of Light-Induced Polyacrylamide Polymerization.
Dimensions (μm)

	<u>Mask #</u>	<u>Gel Cells</u>	<u>Interstitial Spaces</u>
10	1	25	50
	2	40	80
	3	100	200
	4	500	1,000
15	5	1,000	2,000

After assembly, the assembled polymerization unit 10 is placed under a light source, such as a 312 nm UV-transilluminator such that the quartz substrate is closest to the source. Good results are obtained when the actual photomask layer 20, first deposited on the first surface of the quartz substrate 14, is in contact with the acrylamide solution. UV exposures of approximately 20 minutes provide good results. A myriad of wavelengths are suitable for the light-induced polymerization process, including those found in the range of between approximately 250 nm and 320 nm.

After exposure, the chamber 10 is disassembled. To facilitate disassembly, the chamber 10 can be placed in a water bath at room temperature. As noted supra, gel matrix units 22 are retained on the glass where light is allowed to permeate through

the mask. These units 22 are separated from each other as a result of opaque mask portions, between the unit regions, precluding gel polymerization.

The resulting gel matrix is washed with water, placed in a solution for a period of time to introduce primary amino groups into the acrylamide (an exemplary solution being hydrazine hydrate). This period of time can range from 35-45 minutes. The matrix is then washed with water, and then treated to neutralize the remnants of the basic pH hydrazine treatment. One such neutralization procedure is placing the matrix in 1 percent acetic acid until neutralization is achieved, perhaps for 10 minutes. After neutralization, the matrix is washed with water, and then treated to remove any electrostatically sorbed chemicals. One such treatment involves placing the matrix in 1 M NaCl for approximately 10 minutes. After a final washing with water, the unit is left to dry, and then treated with a thin film of an anti-wetting agent, such as Repel-Silan so as to make the interstitial glass spaces, designated as "B" in FIG. 3, hydrophobic. This will further isolate the gel units 22 from each other to minimize cross contamination during oligonucleotide loading. Treatment of the anti-wetting agent is brief, approximately 1 minute. The matrix is rendered ready for oligonucleotide loading after a final washing with ethanol (from 96 percent to neat) and then water to remove the ethanol.

25 Oligonucleotide Loading Detail

The inventors have developed a specific method for loading oligonucleotides onto matrices which are produced via the method outlined above. The method is fully disclosed in PCT 93 040902,

filed on August 11, 1993 to Mirzabekov and incorporated herein by reference. Described briefly, a pin is immersed into, and is wetted with, oligonucleotide solution. After being withdrawn from the solution, the pin is contacted with the gel surface.

5 During oligonucleotide aspiration, transfer and deposition, the temperature of the pin must be maintained near dew point at ambient temperature so as to prevent evaporation. Otherwise, the viscosity of the solution micro-volumes (typically 10 nanoliters or less) will lead either to complete evaporation or to incomplete
10 transfer of the desired dose.

The invented transfer method allows for the transfer of a range of micro-volumes of oligonucleotide solutions, from 0.3 to 50 nanoliters (nl), with a dispensing error of no more than approximately ± 20 percent.

15 Oligonucleotide Immobilization Detail

The inventors have developed an immobilization procedure for coupling micromolecules to acrylamide gels so as to minimize liquid evaporation during immobilization and to also ensure that covalent bonding of oligonucleotides to the gel matrix units
20 proceeds to completion. This procedure is more fully disclosed in PCT 93 040901, filed on August 11, 1993, to Yershov, and incorporated herein by reference.

Briefly, the immobilization process is as follows: Micro-volumes of bioorganic solutions are loaded onto the micro-matrix
25 cells, with the temperature of the micro-matrix being maintained equal to that of the ambient air. Once the micro-volumes of the oligonucleotide solutions have been applied to the cells of the matrix, the micro-matrix temperature is set equal to or below the

d w point of the ambient air. This temperature is maintained until swelling of the gel is complete and noncoalescent droplets of water condensate appear in the spacings "B" between the cells.

After the appearance of the water condensate, a thin layer
5 of an inert, nonluminescent oil is applied to the micro-matrix surface so as to prevent oligonucleotide evaporation. An oil layer of at least approximately 100 μm provides good results. A myriad of inert oils are suitable including, but not limited to, purified Vaseline®, phenyl (10 percent) methylsilicone oil, phenyl (20
10 percent) methylsilicone oil, among others.

The micro-matrix is kept under the oil layer until completion of the oligonucleotide immobilization process, and preferably for 48 hours. The oil is then removed by washing with a polar substance that will not cause oligo denaturing, such as ethanol, or
15 water. The matrix is dried and stored indefinitely, ready for use.

An exemplary embodiment of the duplex detection method, incorporating the produced micro-matrix topologies, is schematically depicted in FIGS. 4A-B as numeral 200. FIG. 4A depicts an oligomer, 212, immobilized to a gel matrix unit 214. The oligomer
20 is constructed to contain an intercalating tag, 216 such as ethidium bromide. Other intercalating agents, such as propidium iodide, also can be employed.

In the free state, depicted in FIG. 4A, wherein the intercalating agent is not juxtaposed between base planes of a duplex, the
25 tag fluoresces at a certain intensity. Part of this fluorescence is due to higher background and lower-signal-to-background noise that results from intercalating dyes reacting with single-stranded oligonucleotides. However, fluorescence is

magnified far above background levels when duplexes do occur. As can be noted in FIG 4B, when a single strand 218 of a target oligonucleotide molecule, complementary to the immobilized oligomer, is contacted with the loaded gel unit, duplexing occurs.

5 The inventors observed that the intercalating agent, now juxtaposed between the base planes of the duplex, fluoresces at an intensity that is approximately 10 times that observed in the free state. This higher intensity is observed within approximately one minute.

10 As an alternative to first binding the intercalating agent to the immobilized oligomer, the intercalating agent can instead be bound to the target single strand oligonucleotide molecule 218. In yet another alternative, addition of the intercalating agent can be made after duplexing occurs between the immobilized oligo
15 fraction 212 and the mobilized single strand target sequence 218.

For example, fluorescence enhancements are achieved when intercalating dyes such as thiazole orange homodimer (TOTO) or oxazole yellow homodimer (YOYO), both of which are manufactured by Molecular Probes, Eugene Oregon. DNA binding fluorochromes
20 specific for double-stranded DNA also provide good results.

Use of AT-specific fluorescent ligands that stabilize these pairs also enhance the fluorescent process by equalizing AT stability vis-a-vis GC-rich interactions.

Example

25 FIG. 5 illustrates the efficiency of using either fluorescently labeled target ss DNA strings (I) or intercalating dyes (II) to rapidly detect duplex formation. This plan view depicts the same matrix of polyacrylamide cells, whereby the

matrix is manufactured by the methods disclosed supra. The matrix is comprised of 16 cells, each cell loaded with the octamer CyAACcXt-5'. As shown, the 3' end is anchored to the gel and not available for further interaction. The immobilized octamer varies
5 at two base positions "y" and "x" as shown along the boundaries of the matrix.

As can be determined in FIG. 5 (I), when the octamer-loaded matrix is hybridized with fluorescently labeled ss DNA, such as the 19-mer CCTGGGCAGGTTGGTATCA, a clear signal is seen when a
10 perfect GC and TA match is made at duplexing. The fluorescent label used in this instance was HEX, available through Applied Biosystems, Foster City, CA. Another suitable dye is tetramethylrodamine.

In a separate experiment, when the octamer-loaded matrix
15 is hybridized with the unlabeled 19-mer in the presence of an intercalating agent, a clear signal again is seen at the GC and TA matching cell location. This can be noted in FIG. 4 (II). Weaker signals also are detected, however. For example, signals were observed when just TA or GC interaction was observed. This
20 indicates that when background noise is controlled, the use of an intercalating agent or a plurality of intercalating agents may be more sensitive, than the use of fluorescent dyes, for detecting at least partial matches when rapid determinations are desired. The intercalating agent used in this instance, ethidium bromide, was
25 added after the duplexing between oligomer strings occurred.

However, and as discussed supra, intercalating agents also can be first attached to either the shorter oligomer strand prior to immobilization. Alternatively, the intercalating agent could be

attached to the target single strand prior to hybridization.

While the invention has been described with reference to details of the illustrated embodiment, these details are not intended to limit the scope of the invention as defined in the

5 appended claims.

The embodiment of the invention in which an exclusive property or privilege is claimed is defined as follows:

- 1 1. A method for determining the existence of duplexes of
- 2 oligonucleotide complementary molecules comprising:
- 3 a.) constructing a plurality of different oligonucleo-
- 4 tide molecules each of a specific length and each having a specific
- 5 base sequence;
- 6 b.) supplying a matrix having a plurality of cells
- 7 adapted to receive and immobilize the oligonucleotide molecules;
- 8 c.) immobilizing the different oligonucleotide
- 9 molecules in the cells to fill the cells;
- 10 d.) contacting the now-filled cells with single
- 11 stranded oligonucleotide molecules to form a duplex;
- 12 e.) contacting the duplex with an intercalating
- 13 agent; and
- 14 f.) observing fluorescence levels emanating from

15 the now-contacted duplex.

1 2. The method as recited in claim 1 wherein the specific
2 length of the different oligonucleotide molecules is selected from
3 a range of between approximately 5 nucleotides and 30
4 nucleotides.

1 3. The method as recited in claim 1 wherein the matrix
2 consists of polyacrylamide.

1 4. The method as recited in claim 1 wherein the interca-
2 lating agent is selected from the group consisting of ethidium
3 bromide, propidium iodide, thiazole orange homodimer, oxazole
4 yellow homodimer, and combinations thereof.

1 5. The method as recited in claim 1 wherein the fluores-
2 cence is observed within 1 minute after duplexing occurs.

1 6. The method as recited in claim 1 wherein the interca-
2 lating agent is covalently attached to the immobilized oligomer.

1 7. The method as recited in claim 6 wherein a first
2 fluorescence level is observed after the oligonucleotide molecules
3 are immobilized to the matrix.

1 8. The method as recited in claim 1 wherein the interca-
2 lating agent is covalently attached to the single stranded oligonu-
3 cleotide molecules.

1 9. The method as recited in claim 1 wherein the interca-
2 lating agent is added after duplex formation.

1 10. A method for constructing oligonucleotide matrices
2 comprising:

3 a.) confining light sensitive fluid to a surface;

4 b.) exposing said light-sensitive fluid to a light
5 pattern so as to cause the fluid exposed to the light to coalesce
6 into discrete units and stick to the surface;

7 c.) and contacting each of the units with a set of
8 different oligonucleotide molecules so as to allow the molecules
9 to disperse into the units.

1 11. The method as recited in claim 10 wherein the light
2 sensitive fluid is comprised of methylene blue solution,
3 acrylamide solution and TEMED.

1 12. The method as recited in claim 10 wherein the light
2 pattern consists of a series of squares.

1 13. The method as recited in claim 12 wherein the squares
2 have dimensions ranging from between 25 microns by 25 microns
3 to 1,000 microns by 1,000 microns.

1 14. The method as recited in claim 10 wherein the steps of
2 exposing said light-sensitive fluid to a light pattern so as to
3 cause the fluid exposed to the light to coalesce into discrete units

- 4 and stick to the surface further comprises
- 5 a.) supplying a transparent substrate with a first
- 6 side and a second side;
- 7 b.) applying an opaque photomask to said first side
- 8 of the substrate;
- 9 c.) removing predetermined portions of the
- 10 photomask to effect a predetermined pattern;
- 11 d.) contacting said first side of said substrate to a
- 12 light sensitive fluid;
- 13 e.) exposing said second side of said substrate to
- 14 light so as to cause the fluid juxtaposed to said pattern to co-
- 15 alesce; and
- 16 f.) removing said light.

1 15. The method as recited in claim 10 wherein the wave-

2 length of light is in the ultra-violet range.

1 16. The method as recited in claim 15 wherein the ultra

2 violet light has a wavelength of 312 nanometers.

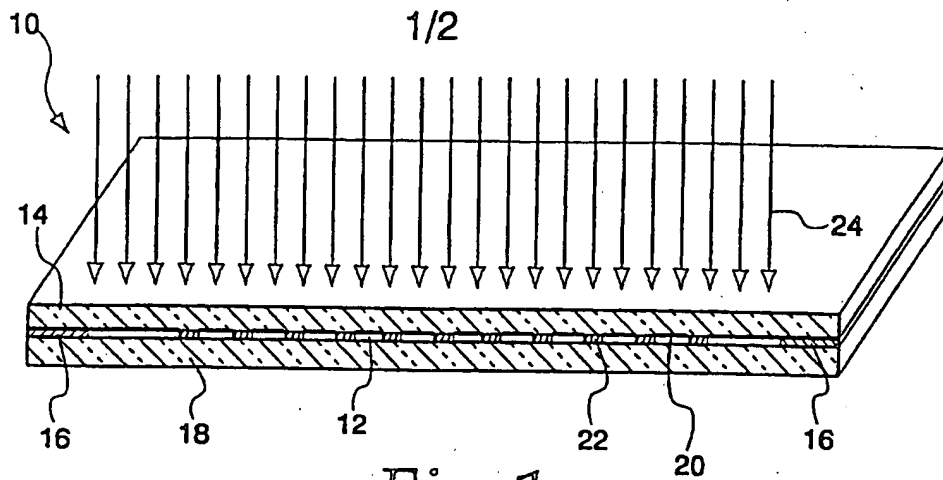

Fig. 1

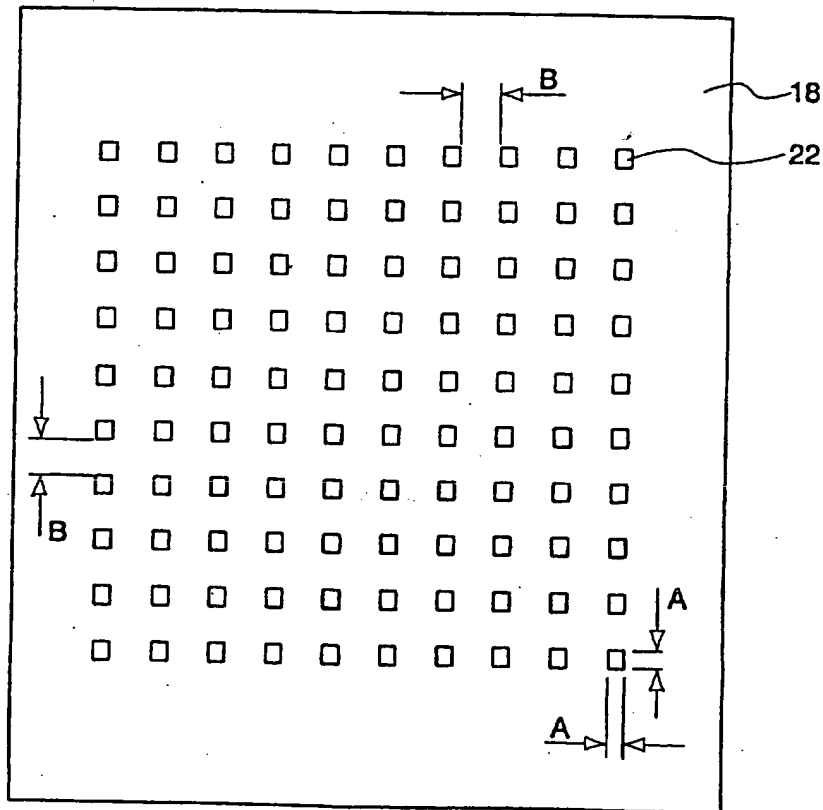

Fig. 3

2/2

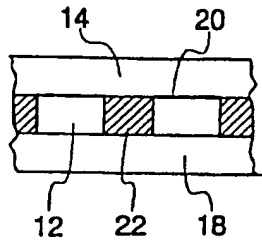

Fig. 2

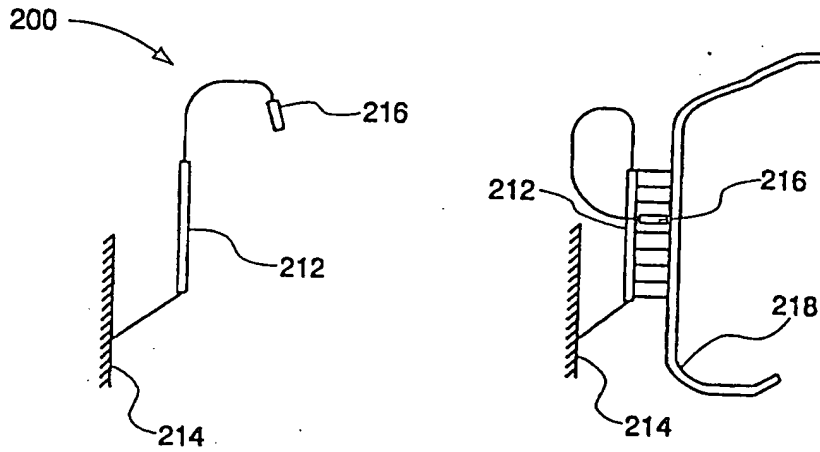
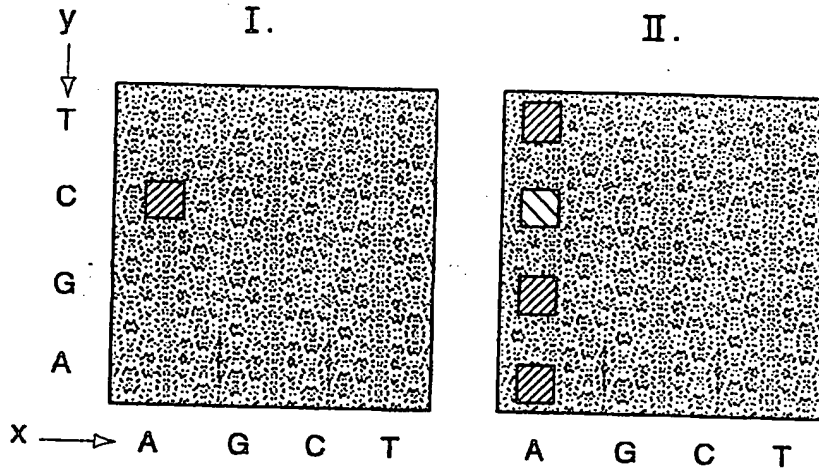

Fig. 4a

Fig. 4b



CCTGGGCAGGTTGGTATCA
 matrix-CyAACCxT-5'

Fig. 5

INTERNATIONAL SEARCH REPORT

International application No.
PCT/US97/01219

A. CLASSIFICATION OF SUBJECT MATTER
IPC(6) :C12Q 1/68
US CL :435/6
According to International Patent Classification (IPC) or to both national classification and IPC

B. FIELDS SEARCHED
Minimum documentation searched (classification system followed by classification symbols)
U.S. : 435/6, 91.2; 536/22.1, 24.3, 24.33; 436/800, 807, 809, 527, 528; 427/2.11

Documentation searched other than minimum documentation to the extent that such documents are included in the fields searched

Electronic data base consulted during the international search (name of data base and, where practicable, search terms used)
APS, CAS, MEDLINE, BIOSIS
search terms: oligonucleotides, matrix, immobilize, cells, intercalating agent, fluorescence

C. DOCUMENTS CONSIDERED TO BE RELEVANT

Category*	Citation of document, with indication, where appropriate, of the relevant passages	Relevant to claim No.
Y, P	US 5,552,270 A (KHRAPKO ET AL.) 03 September 1996, columns 4-5.	1-16
Y	SOUTHERN, E.M. et al. Analyzing and comparing nucleic acid sequences by hybridization to arrays of oligonucleotides: evaluation using experimental models. Genomics. May 1992, Vol. 13, pages 1008-1017, especially pages 1009-1010.	1-16
Y	WO 95/08642 A1 (ZENECA LIMITED) 30 March 1995, abstract, page 9, 10 and 27	1-16

Further documents are listed in the continuation of Box C. See patent family annex.

A document defining the general state of the art which is not considered to be of particular relevance	*T* later document published after the international filing date or priority date and not in conflict with the application but cited to understand the principle or theory underlying the invention
E earlier documents published on or after the international filing date	*X* document of particular relevance; the claimed invention cannot be considered novel or cannot be considered to involve an inventive step when the document is taken alone
L documents which may create doubts on priority claim(s) or which is cited to establish the publication date of another citation or other special reason (to specify)	*Y* document of particular relevance; the claimed invention cannot be considered to involve an inventive step when the document is considered with one or more other such documents, each document being obvious to a person skilled in the art
O documents referring to oral disclosure, use, exhibition or other means	*Δ* document member of the same patent family
P documents published prior to the international filing date but later than the priority date claimed	

Date of the actual completion of the international search: 31 MARCH 1997
Date of mailing of the international search report: 08 APR 1997

Name and mailing address of the ISA/US Commissioner of Patents and Trademarks
Box PCT
Washington, D.C. 20231
Facsimile No. (703) 305-3230
Authorized officer: LISA ARTHUR
Telephone No. (703) 308-0196